



PRI-50

Model PRI-50 Pictured without loader



Warranty:
2 year parts
Life time on workmanship

COLOR OPTIONS	
Red	
Royal Blue	
Hunter Green	
Black	
Canary Yellow	
Burgandy	

©2003 Primo Roasting Equipment

Technical Specifications

Batch Capacity 18% Weigh Loss	Max Green 70 lbs.	Roasted. 57lbs.
Roasted Capacity per hour.		225 lbs.
Crated Shipping Weight.		1800 lbs.
Dimensions	73" High x 66" Deep x 29" Wide Not including roaster cyclone	
Electrical	110 V = 25.5 amps	220 V = 7.5 amps
CFMS	Roasting = 360	Cooling = 1125
Gas Supplied 3/4" inlet	Natural	Propane
Venting	Cooler = 6"	Cyclone = 6"

Standard Features

- Two-stage digital temperature controller.
- Speed Controller
- Chaff cyclone collector
- Brushed Stainless Face Plate
- Aluminum Trim.
- IR Burners

Upgrades Available

- Custom Paint
- Fire Suppression in Cyclone
- Vacuum Green Coffee Loader

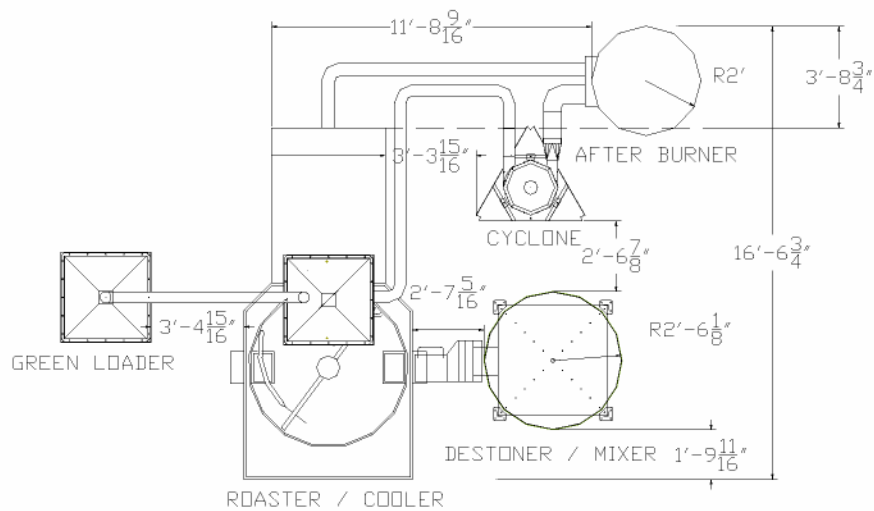

WITH AFTERBURNER

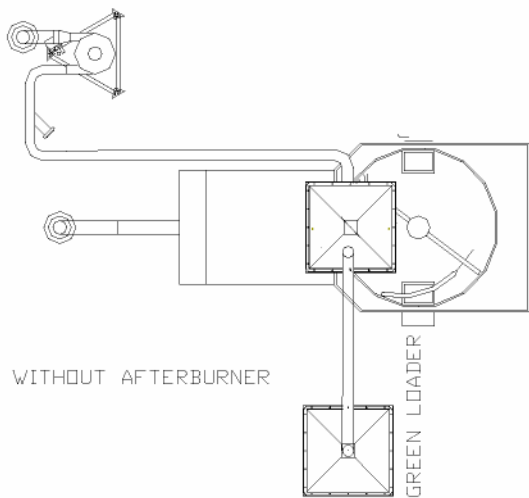
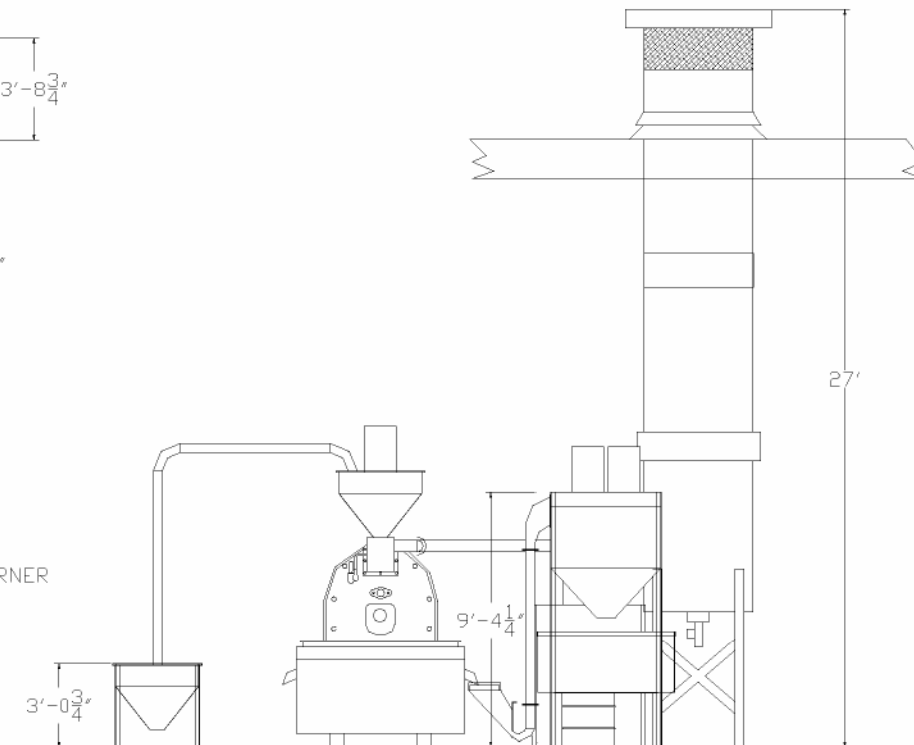

PRI-50 Layout Sheet

PRI 50

REV. 1 09/12/02

TOM OVERY

PRIMO ROASTING INC.
1717 NEWPORT CIRCLE
SANTA ANA, CA 92705
1-714-556-5259